

Temperature. °C.	Specific heat of saturated vapor. Joules/g. deg.	Temperature. °C.	Specific heat of saturated vapor. Joules/g. deg.
-45	-4.42	0	-3.54
-40	-4.29	+5	-3.48
-35	-4.17	+10	-3.43
-30	-4.05	+15	-3.40
-25	-3.95	+20	-3.36
-20	-3.85	+25	-3.34
-15	-3.76	+30	-3.33
-10	-3.68	+35	-3.33
-5	-3.61	+40	-3.34
0	-3.54	+45	-3.36

WASHINGTON, D. C.

[CONTRIBUTIONS FROM THE RESEARCH LABORATORY OF PHYSICAL CHEMISTRY OF THE MASSACHUSETTS INSTITUTE OF TECHNOLOGY. No. 112.]

THE VAPOR PRESSURE OF LIQUID AMMONIA UP TO THE CRITICAL TEMPERATURE.

[PART II.]

BY FREDERICK G. KEYES AND R. B. BROWNLEE.

Received November 11, 1917.

CONTENTS.—1. Previous Investigations. 2. The Experimental Method and Description of the Apparatus. 3. Data and Method of Determining the Vapor Pressure as a Function of the Temperature. 4. Summary.

I. Previous Investigations.

The earliest attempt to measure the vapor pressure of liquid ammonia appears to be due to Faraday¹. The measurements extend from -17.77 to $+28.33$. At that time precise thermometry had not been developed, and, moreover, no very great precautions were taken to avoid the presence of permanent gas or other impurities soluble in liquid ammonia. The presence of permanent gas such as air in a liquid is most difficult to remove. It is in fact not possible to remove it by simply pumping away vapor or even sufficiently by freezing and pumping the vapor from the crystals.² The Faraday measurements, while not as accurate as may now be obtained with modern experimental facilities, are nevertheless within a few per cent. of the values obtained by Regnault.³

Regnault's data are given in three series of measurements each under different experimental conditions. The third series were made by means of a closed air manometer, thus requiring an accurate knowledge of the pressures corresponding to the various volumes of compressed air read from the manometer. The pressures assigned to the volume readings of the manometer were not accurately known and in consequence the ammonia

¹ Faraday, *Phil. Trans.*, 135, 170 (1845).

² Young, *Phil. Mag.*, 20, 797 (1910).

³ Regnault, *Mem. l'Inst. France*, 26, 598 (1847).

vapor pressures in the third series are smaller than those given by the dynamic method used in making the observations given as Series 1 and 2. It would be of course possible to recompute the manometer readings; but the addition to the knowledge of the vapor pressure—temperature relation was thought to be too small to compensate for the labor involved, inasmuch as new measurements were to be made utilizing modern facilities. The closed air manometer measurements are ten in number extending from 10° to 80° .

There are further measurements published since Regnault's work by Blümke,¹ Brill,² and Davies.³ The Blümke measurements were made from ammonia prepared from ammonia water and consist in all of four measurements from -18.5° to 63.5° . Except for the value obtained at 63.5° the values of the vapor pressure obtained are lower than the smoothed Regnault values. The pressures were read from an air manometer and use was doubtless made of the isotherms of air as determined by Amagat.⁴

The values given by Brill were obtained for the purpose of testing the form of function deduced by Nernst by the aid of the Nernst theorem, for the vapor pressure as a function of the temperature. The particular form required that the measurements be made in the temperature region where the specific volume of the saturated vapor was large compared to that of the liquid. The method employed by Brill consisted in passing air over the liquid ammonia maintained at constant temperature. The weight of ammonia in a known volume of air was then determined by passing the gas mixture into dilute acid and titrating.

The partial pressure of the ammonia was calculated by making use of the perfect gas law and Dalton's law. Evidently the accuracy of the method depends on the fulfillment of the latter laws by the mixture of air and ammonia gas. For pure ammonia gas at the saturation specific volume corresponding to -33° , the departure from the perfect gas law approaches 1%. There is no means of foretelling the deviation for an air-ammonia mixture. The most serious practical difficulty, however, in carrying out the measurement is perhaps involved in obtaining a close approximation to equilibrium in the streaming air. The measurements extend from -80.0° to -33.0° , and the boiling point under 760 mm. pressure is given as -33.1 .

The measurements due to Brill are the most comprehensive in the region below the boiling point; and, in spite of the trend introduced into the results by the simplified assumptions used in calculating the data over to vapor pressures, there can be considerable confidence placed in the

¹ *Ann. Phys.*, [2] 34, 18 (1888).

² *Ibid.*, [4] 21, 170 (1906).

³ *Proc. Roy. Soc. London*, A78, 41 (1906).

⁴ *Compt. rend.*, 99, 1153 (1884).

pressure values corresponding to the lowest temperatures where the simple method of calculating would be most valid.

The measurements contributed by Davies were made in part for the purpose of establishing the boiling point of pure ammonia. A simple mercury manometer was used to measure the pressures and a pentane thermometer for the temperature measurements. The latter was calibrated by comparison with an air thermometer. The measurements extend from -50° to -5° and agree tolerably with the values given by Regnault's smoothed curve. There was no particular provision for precise temperature regulation of the carbon dioxide snow and alcohol bath employed by Davies. The experience of the writers has been that equilibrium between a vapor and its liquid is not quickly attained, particularly at lower temperatures. In fact it was found necessary to maintain the temperature of the thermostat at a constant value for about one-half hour, during which time the liquid was stirred or shaken, to ensure equilibrium being attained. The lag in coming to equilibrium appears to be increased as the liquid is freed more perfectly from dissolved gases. In the case of ether, for example, the liquid may be superheated 20 to 36° when very perfectly freed from dissolved air. Shaking or stirring the liquid ether, however, brings about equilibrium fairly rapidly, explosively of course if the degree of superheating has been large.

A more comprehensive discussion of the relation between the vapor-pressure measurements due to the various observers will be presented below where comparisons will be shown with the data furnished by the present investigation.

2. The Experimental Method and Description of Apparatus.

The experimental methods employed in the present work embody nothing essentially new except for certain minor details of manipulation which the particular properties of the liquid ammonia required. The ammonia used was obtained from the National Ammonia Co. of Philadelphia. A suitable quantity of the ammonia was drawn into a small steel cylinder containing metallic sodium and allowed to stand for a considerable time to ensure complete reaction of the water with the metallic sodium. The ammonia vapor from the auxiliary tank was subsequently passed into dry ammonium nitrate contained in the glass apparatus *c*, *b*, *a*, Fig. 1. This procedure made it possible to keep the ammonia at ordinary temperatures without undue pressure and permitted weighings to be made of the ammonia distilled out of the glass container. It was possible, moreover, to very completely remove dissolved gases from the ammonium nitrate-ammonia solution. The difficulty of removing with sufficient completeness the dissolved gases does not seem to be particularly emphasized in the descriptions of the methods of manipulation heretofore employed in the measurements pertaining to ammonia. The liquid appears

to be capable of retaining considerable quantities of permanent gas. The paper by Young already referred to, makes clear the difficulty of removing gases in the case of ether. In the present work a glass bomb was used in the preliminary work and the collapsing of the vapor phase completely without rise in pressure was taken to indicate the absence of permanent gas. This method is not nearly so sensitive as the method of testing suggested by Young in his paper where use is made of an inverted bell which can be raised by means of a magnetic arrangement thereby trapping a portion of the gas phase. If the gas phase collapses under the slight hydrostatic head of liquid there can assuredly be very little gas present.

Except for a few measurements made as preliminary studies all the measurements above zero were carried out in steel containers. Two steel bombs were employed during the course of the work and they will be re-

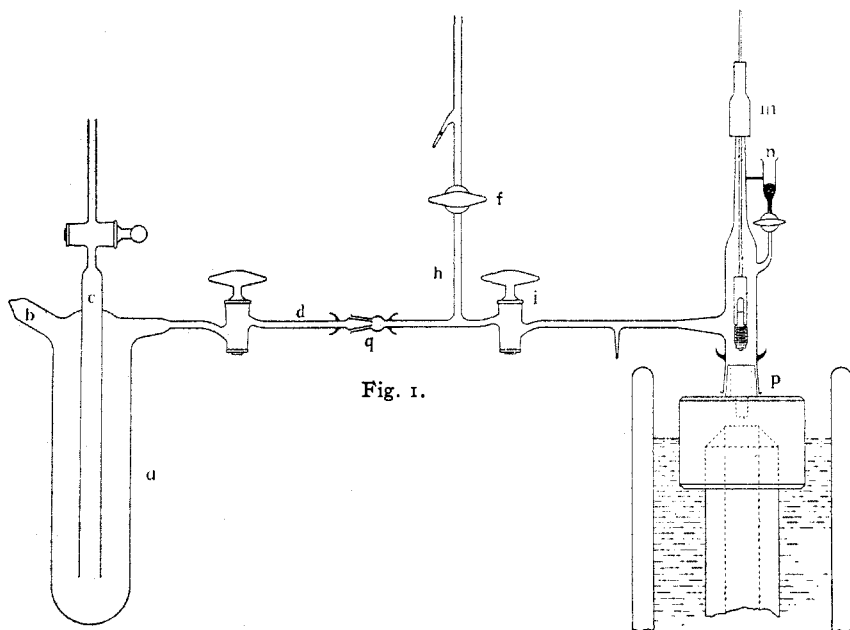

ferred to as steel bombs one and two. Steel bomb one is shown in Fig. 2 and was designed to withstand a pressure of 100 atmospheres. Steel bomb two represented partially in Fig. 1 was designed to withstand a pressure of about 1500 atmospheres. The type of the glass bombs is represented in Fig. 3 together with the method employed in making the pressure tight connection between the steel at (a) and the glass. The glass capillary was expanded and ground to fit the tapered steel piece after which it was cemented into place with a shellac and oil of tar composition. These joints have been used for a number of years in this laboratory and with-

stand the pressure to the bursting limit of the glass apparatus attached by means of the joint.

The methods employed in loading the bombs are clearly shown in the figures. In the case of the glass bomb, Fig. 3, the glass portion of Fig. 1, *b*, *d*, *i*, with the exception of *m*, *n*, *p*, was sealed to the extension from *b*, Fig. 3. The ammonia container *c*, *b*, *a* was weighed and connected by means of the ground joint at *q*. The bomb and connecting tubes could be completely exhausted through *f* and after cooling the glass bomb *b* to about -38° the ammonia from *c*, *b*, *a* could be condensed to the desired amount. The bomb was finally sealed at *b* and the ammonia container *c*, *b*, *a* again weighed. The ammonia in the leads *d*, *h*, *i* was allowed for in determining the weight of ammonia contained in the bomb. The first

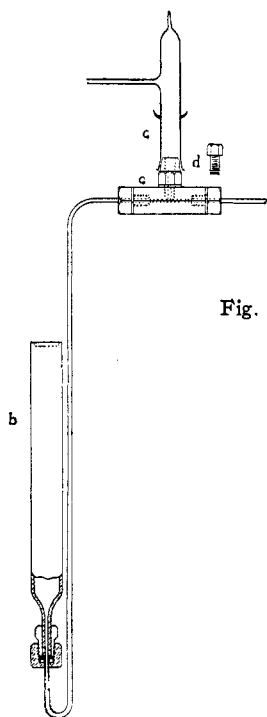

Fig. 2.

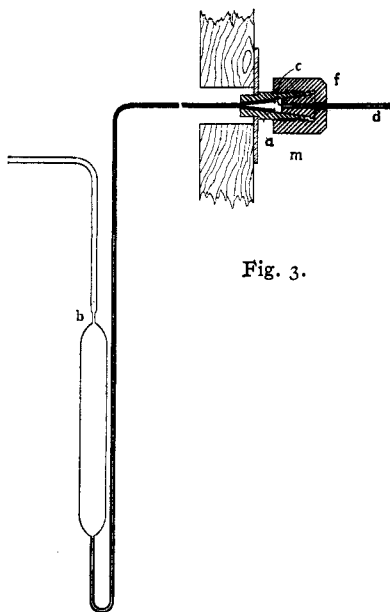

Fig. 3.

determination of the specific volumes of liquid ammonia were made in the glass bomb for which purpose the volume of the bomb had been determined to a mark on the capillary connecting tube. The data obtained, however, were later discarded in favor of specific volumes determined by a more accurate method.

The loading procedure for each of the steel bombs was different. These bombs were used for measuring the liquid and vapor isotherms as well as the vapor pressures and a definite weight of ammonia was therefore always intro-

duced. The loading apparatus referred to in Fig. 1 was attached to *c*, Fig. 2, and after the desired quantity of ammonia had been condensed in *b* mercury was passed over from the compressor connected by means of a capillary steel tube to the right of *e*, Fig. 2. After the mercury had sealed the contents of *b* to the air, the ground glass portion *c* was removed and the locking plug *d* screwed securely into its seal. The heavier nickel steel cylinder of Fig. 1 required the locking plug to be screwed home partially by means of the wrench handle projecting through the rubber at *m*. Mercury could be flowed about the plug from *n* and thus sealed the contents of the bomb from the air until the locking plug could be securely seated. The sliding rubber connection for the temporary wrench at *m* was well covered with stopcock grease and during preliminary trials showed no leak. Of course at the moment when the wrench was manipulated ammonia at about atmospheric pressure filled the inside of the apparatus, thus preventing the entrance of air during this part of the manipulation.

The general disposition of the apparatus used to measure volume changes and pressures is shown in Fig. 4. The compressor 10, 12, 13, 14 was entirely submerged in an oil bath which kept the temperature constant to a few hundredths of a degree. The piston of the compressor was advanced by means of the screw 14 and the nut 15. The position of the piston could be read by means of the counter at 20 and the nut 15 whose periphery was divided into 100 parts thus permitting the estimation of thousandths of a turn. At 21 a riser of glass capillary was placed, use being made of the metal glass ground joint already described in connection with the glass bomb of Fig. 3. This riser had a mark several inches above the steel block 10 and the mercury was always kept at this mark by injecting oil from a pump attached to the rear face of the piston block 34. From 10 connection was made directly with the bomb about which the bath was placed. The temperature-regulated bath contained the usual heater and mercury regulator, stirrer and thermometers. The small mercury injector 38 was attached to the mercury regulator for the purpose of facilitating and reproducing settings of the regulator corresponding to specified temperatures.

The present paper deals with the vapor-pressure measurements alone, reserving for the paper dealing with the specific volumes those details concerning the use of the apparatus in measuring volume changes. It remains, however, to discuss the pressure measuring device and the calibration of the measuring piston. The piston and its cylinder were made by the Brown and Sharp Co. of Providence, R. I. Both were tempered and the piston left glass hard. After two years' use the piston showed no wear and the fit of the piston into its cylinder is so perfect that at the highest pressures employed (1000 atm.) it showed a very moderate leak. The

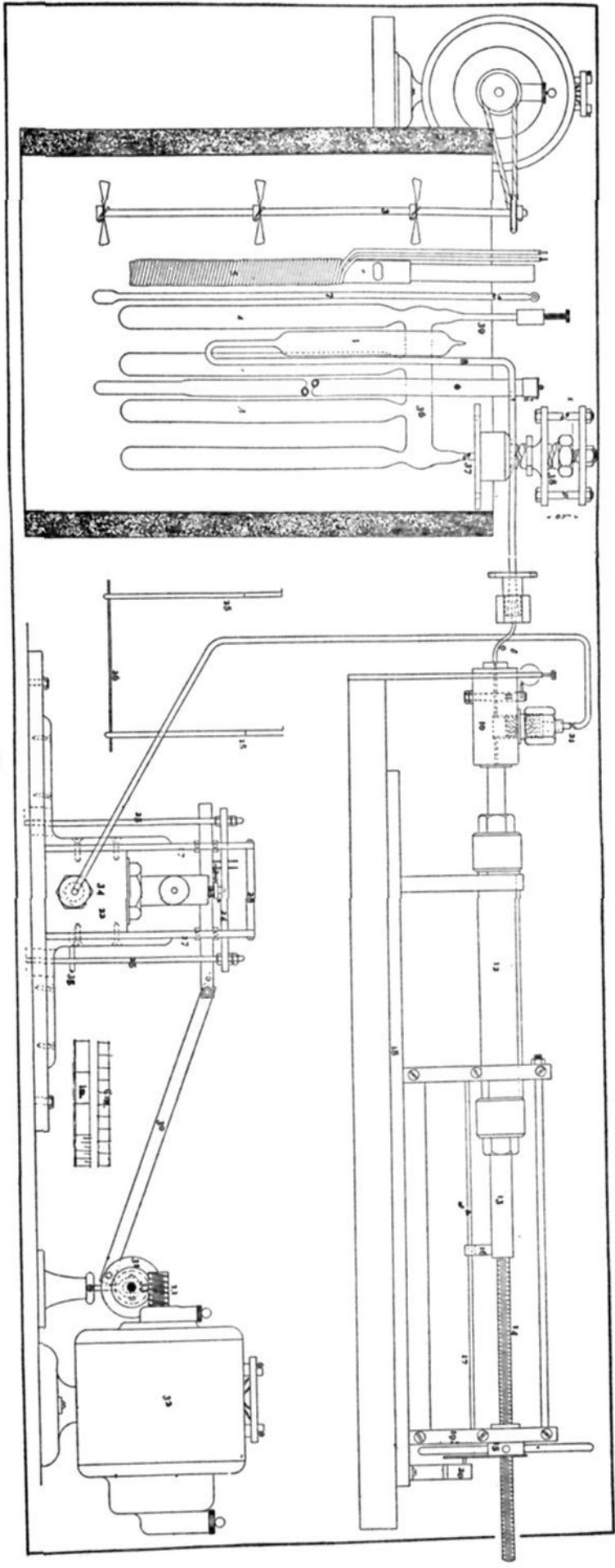

Fig. 4.

diameter of the piston was by measurement¹ 0.47544 cm. 20°. The figure shows the means adopted to reciprocate the piston through a small angle. It is necessary to reciprocate the piston by some means to secure prompt equilibrium between the pressures within the cylinder and the equilibrating weights on the scale pan attached to 25 and 24°.

The calibration of the piston proved a most troublesome and unsatisfactory process as originally carried out. It appears that the usual practice in using the absolute pressure gage has been to observe the rise or fall of the piston due to a deficiency or excess of equilibrating weight. This, for example, was essentially the method of determining the equilibrium adopted by Holborn and Bauman² in their work on the vapor pressure of water. The constant of their gage or effective area was obtained by calibration against a mercury column. Four comparisons were made by means of a mercury column between 930 cm. and 1160 cm. in length. If it is assumed that the pressure is given by cw where c is a constant of the piston and w the weight on the piston area expressed in g., the constant c will vary inversely as the effective piston area. For the range of the Holborn and Bauman calibration c appeared to be constant to about one part in ten thousand.

Bridgman³ has discussed, as completely as at present possible, the corrections due to the stresses produced by the hydrostatic pressure in a gage of the type here considered. The present elasticity theory as pointed out by Bridgman, is not sufficiently complete to enable the complete evaluation of the corrections when high pressures are to be measured. For the moderate pressures (1000 atm.) for which the present gage was designed, however, the change in the effective area of the piston due to the hydrostatic pressure is negligible.

It was discovered that the effective area, or rather the constant c of the gage, turned out in the preliminary comparisons with the mercury column to be a function of the pressure. This constant, for example at 565.2 cm. mercury height, appeared to be 4.103 while at a column height of 1238.3 cm. the constant was 4.1214, a difference of 0.52%. The study of a large number of observations disclosed the fact that as higher pressures were approached the value of c would probably approach constancy or 4.1362 at about 70 atmospheres. This resulted from employing an empirical equation which represented the "constant" as a function of the pressure accurately. The search for a more sensitive method of detecting equilibrium has established the fact that for this particular piston the method of direct visual detection of its rise or fall is not adapted for ob-

¹ The measurement was made on the large Pratt and Whitney machine of the Mechanical Engineering Department of this Institute.

² *Ann. Phys.*, [4] 31, 945 (1910).

³ *Contrib. Jefferson Physical Lab.*, 6, 201 (1906).

servicing small absolute pressures and, furthermore, confirmed the conclusions of Bridgman regarding the invariability of the effective piston diameter when fluid is escaping around the piston.¹

The method of detecting the true weight necessary to equilibrate the pressure consisted in utilizing the volume displacement of the piston due to its rise or fall to cause mercury to move in a capillary. The vertical motion of the piston was thus magnified and a telephone receiver used in connection with an induction coil secondary circuit further increased the sensitiveness with which a displacement of the capillary mercury surface could be detected.

TABLE I.

Calibration of the Pressure = Measuring Piston with Electric Contact for Determining the Equilibrium of Piston.

Mean temp. of column.	Density of mercury.	Grams on piston.	Total corrected weight.	Height in feet.	Cor- rection for oil level.	Correc- tion for length tape. Mm.	Mm. at 0°.	Constant of piston.	Per cent. deviation from mean value 4.1351.
Series 1.									
27.68	13.527	3035.0	3037.4	41.578	-50	-3.8	12556.0	4.1338	-0.032
26.48	13.530	1914.7	1916.5	26.291	-50	-2.3	7923.1	4.1342	-0.022
25.66	13.532	1538.2	1540.1	21.151	-50	-1.7	6365.5	4.1332	-0.046
24.87	13.534	1168.2	1169.5	16.121	-50	-1.3	4840.6	4.1390	+0.094
24.67	13.535	837.5	838.4	11.593	-50	-1.0	3467.1	4.1354	+0.007
24.37	13.536	586.4	586.9	8.190	-50	-0.7	2435.0	4.1489	huge error
23.91	13.537	410.4	410.5	5.765	-50	-0.5	1699.4	4.1399	+0.11
Series 2.									
26.38	13.531	2627.75	3026.0	41.400	-50	-3.9	12505	4.1327	-0.058
26.38	13.531	2627.25	3025.5	41.388	-50	-3.7	12502	4.1322	-0.070
26.38	13.531	2626.00	3024.25	41.362	-50	-3.7	12494	4.1313	-0.092
26.21	13.531	1469.25	1867.31	25.620	-50	-3.2	7719	4.1338	-0.032
26.21	13.531	1467.15	1865.2	25.617	-50	-3.2	7718	4.1379	+0.068
26.21	13.531	1467.6	1865.65	25.610	-50	-3.2	7716	4.1358	+0.017
26.21	13.531	1467.4	1865.35	25.607	-50	-3.2	7715.1	4.1360	+0.022
26.21	13.531	1467.0	1865.05	25.596	-50	-3.2	7711.7	4.1348	-0.007
26.21	13.531	1464.8	1562.9	25.580	-50	-3.2	7706.9	4.1370	+0.046
26.28	13.531	646.6	1043.8	14.425	-50	-1.3	4324.7	4.1432	huge error

Density of mercury at 0°, 13.595.

Mean value of constant 4.1351 = 0.0005.

Fig. 5 is a representation of the disposition of the apparatus during calibration against the mercury column and the same principle was made use of finally to measure the pressures throughout all the work. Referring to the diagram the gage and part of the reciprocating mechanism is shown at R. The base block into which the piston is screwed has two leads, one connecting with an oil injector, D, to supply oil lost by leakage about the piston and the other leading to the steel device A. From A the

¹ It is undoubtedly true that a piston fitting its cylinder less exactly than the one here discussed would be more suitable for direct observation.

connection continues to the steel cylinder M which contains sufficient mercury to fill the mercury column H when oil is injected by means of the Cailletet pump, the connection to which is shown in the figure. The motion of the mercury at its junction with the oil at N in the steel capillary A was observed by means of the telephone receiver connected in series with the

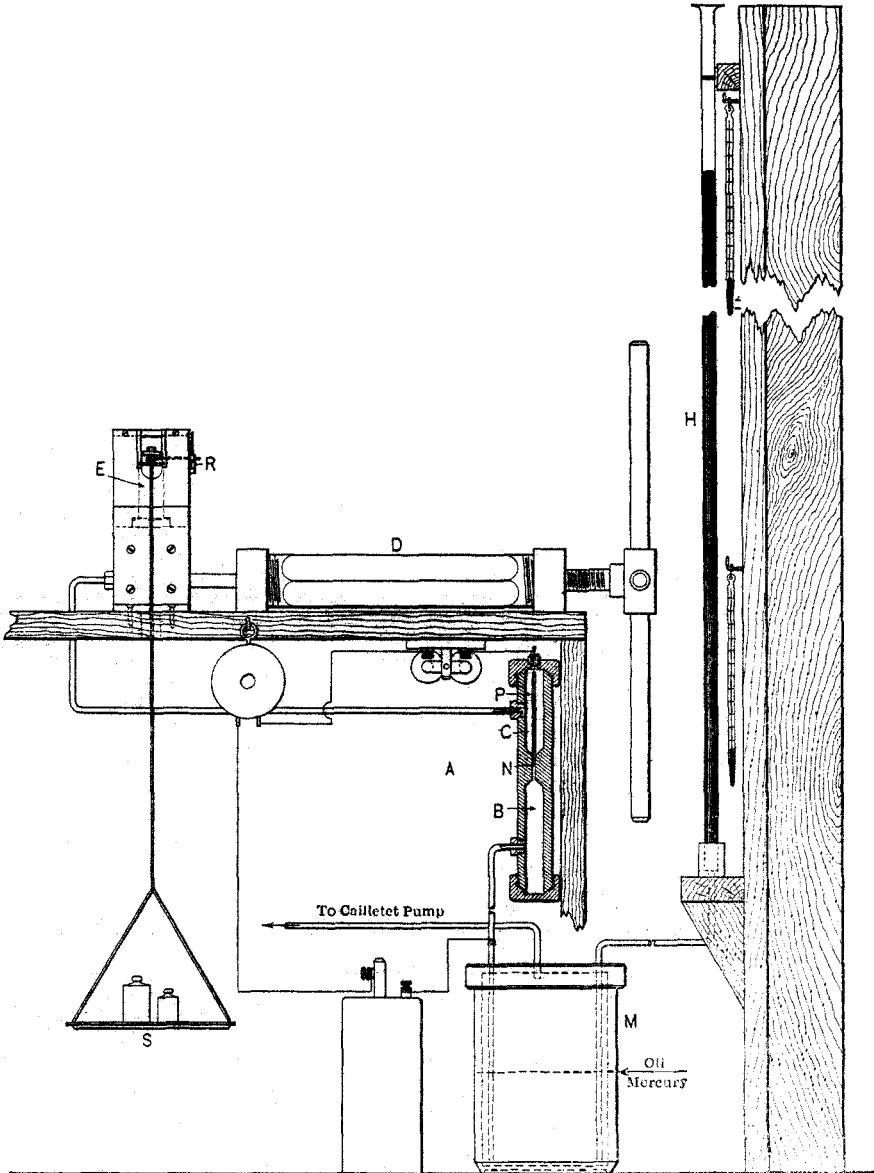

Fig. 5.

secondary of the small induction coil as represented in the figure. An insulating joint is provided, through which passes a pointed wire. When the weights on the scale pan S are insufficient the mercury will rise in the capillary at N and excite the telephone receiver and, conversely, if in excess will break the circuit. If it is desired to verify the observation the circuit is broken by the injection of a minute quantity of oil by means of the oil injector D moving the piston to a new position. The weights could be adjusted throughout the range of the calibration so that 0.1 g. caused contact to be broken and the removal of the 0.1 g. renewed contact. Since the diameter of the capillary was about 0.15 cm. while the diameter of the piston was 0.476 it is evident that a motion of 0.01 cm. of the piston corresponds to a vertical motion of 0.1 cm. of the mercury in the capillary or a magnification of about tenfold. The diameter of the hole into which the piston fitted was only about 0.001 cm. greater than that of the piston itself and the rate of leak under the calibrating pressures amounted to but 1.2×10^{-5} cc. per minute per atmosphere and proved not sufficient to interfere with accuracy. The method has been used for all the work requiring pressure measurements in this laboratory and has greatly reduced the time required to make pressure measurements as well as increased the accuracy with which measurements could be made.

It is of course important in comparing the piston with the mercury column to determine the true mean temperature¹ of the column and this was obtained by reading the temperatures of a number of thermometers set along the column. By plotting the temperature readings as ordinates with the heights of the thermometers along the column as abscissas it is possible by graphical integration, using a planimeter, to evaluate the true mean temperature.

TABLE II.

Measurements of the Diameter of the Piston Used in Measuring Pressures.

	I.	II.	III.
Top of Piston	0.18720	0.18720	0.18720
	0.18720	0.18720	0.18720
	0.18715	0.18713	0.18713
	0.18720	0.18720	0.18720
	0.18715	0.18714	0.18715
	<hr/>	<hr/>	<hr/>
	0.18718	0.187174	0.187176

Average diameter 0.18718 inches or 0.47544 cm. The computed constant for the pressure piston is accordingly 4.1442.

Table II shows the data obtained by measuring the diameter of the piston directly at three diameters and at five equispaced points along the

¹ It is believed now, four years after completing this work, that the chief source of error lies in controlling the temperature of the mercury column since the electrical contact method of determining equilibrium is extremely sensitive. One degree of temperature would cause a difference of one part in 5500 in the density of mercury.

length of the piston. Each number is the mean of three settings of the electrical contact points of the measuring machine. Table III gives the calibration data obtained for the steel tape used. The comparison was made on a comparator of the Physics Department of this Institute using the department's standard meter made by the Societe Genevoise. The data show that the steel tape was 4.66 mm. too long at 51 feet or about one part in thirty-three hundred at 25°.

TABLE III.

Calibration of the Steel Tape at 25° Used in Calibrating the Pressure Piston.

Tape Reading.	Correction.	Tape Reading.	Correction.
0 to 3'	—0.54 mm.	27'-30'	—0.30
3'-6'	—0.20	30'-33'	—0.26
6'-9'	—0.18	33'-36'	—0.20
9'-12'	—0.34	36'-39'	—0.24
12'-15'	—0.20	39'-42'	—0.30
15'-18'	—0.28	42'-45'	—0.14
18'-21'	—0.34	45'-48'	—0.50
21'-24'	—0.30	48'-51'	—0.24
24'-27'	—0.10		

The density of mercury as effected by geographical position was taken into consideration in reducing the mercury heights and thus the pressures given in Table I refer to sea level at 45° of latitude and zero degrees. The weights used on the scale pan were of course calibrated. The various data of the calibration are collected in Table I.

The observations are divided into two series made at different times, and about half the observations were made independently by Mr. R. D. Mailey of this laboratory. The mean value of the constant of the gage is concordant in the two series to about one part in eight thousand. It is also evident that the constant is invariable as the height changes from about 1700 mm. to 12560 mm. or for about a sevenfold change.¹ The value of the gage constant 4.1351 mm. per g. is also seen to be in very good agreement with the extrapolated value 4.1362 obtained by the method of direct observation of the motion of the piston.

Table I shows that the method of observation by electrical contact enables a short mercury column to be used to determine the gage constant accurately. The method of direct observation of the rise or fall of the piston, on the other hand, at least in the case of the piston used in the present work, is unreliable for observing small pressures. Both methods of observation for the higher pressures (50 atm.) have been used in the

¹ The diameter of the piston by direct measurement is 0.47544 while the apparent diameter from the constant obtained by direct calibration is 0.47597. The effective diameter as pointed out by Bridgman is the mean of the diameters of the piston and hole. The diameter of the hole was, therefore, 0.00106 cm. larger than the piston. The design of the piston cylinder was not such as to permit an accurate direct measurement of the diameter of the hole.

present paper, but the readings by the electrical contact method were much more concordant.

3. Data and Method of Determining the Vapor Pressure as a Function of the Temperature.

The preliminary vapor-pressure measurements were carried out in a glass bomb for the purpose of determining whether the ammonia distilled into the bomb from the container represented at *a*, Fig. 1 was free from permanent gases. It was found that the vapor phase collapsed promptly with no rise in pressure showing that permanent gas was absent. The measurements made in the glass apparatus were not carried to a temperature higher than 30°, however, owing to the danger of explosion. The two steel bombs used for the higher pressure work were each used to carry out two series of measurements at the higher temperatures.

All the measurements reduced from the direct observations of the vapor pressure of liquid ammonia are contained in Table IV. The temperatures at which the pressures were measured were determined in the beginning of the work by means of a mercury thermometer, but shortly after completing the measurements made in the glass apparatus use was made of a 25 ohm platinum resistance thermometer. The mercury thermometer was compared with the platinum thermometer and subsequently all mercury thermometer readings were corrected and may therefore be considered referred to the constant volume nitrogen scale. The latter temperature scale for the range of temperatures employed in the present work is of course substantially equivalent to the absolute temperature scale.

The measurements tabulated in Table IV are given in terms of mm. of mercury at 0° at 45° of latitude and sea level. They depend directly of course on the weights required to equilibrate the piston gage whose calibration has already been discussed, except for corrections due to oil and mercury levels pertaining to the apparatus in which the measurements were made. The volume of the vapor phase above the liquid throughout each of the measurements was varied from practically zero to the maximum which the apparatus permitted and each value given consequently depends on several settings of the volume piston.

For convenience in treating the data an equation expressing the logarithm of the pressure as a function of the temperature was worked out using all the measurements as given in Table IV. This equation was then used to obtain the rate of change of the vapor pressure with the temperature and the individual measurements reduced to round temperatures. The reduced measurements are collected in Table V and the concordance of the several measurements at the same temperature is thus obtained. There is included in this table a number of measurements made in a special apparatus at about the boiling point of liquid ammonia. This apparatus constructed with an electromagnetic stirrer provided effective

TABLE IV.—EXPERIMENTAL DATA.

T. Series No. 1.	p. Soda glass bomb.	T. Series No. 1.	p. Steel bomb No. 1.	T. Series No. 1.	p. Steel bomb No. 2.
0°	3267	0	3153	29.825	8742
0	3275	24.64	7519	29.853	8735
0	3276	29.84	8746	34.86	10126
0	3285	34.96	10195	49.83	15226
19.90	6457	39.87	11697		
19.98	6473	40.37	11836		
20	6475	45.02	13424	Series No. 2.	Steel bomb No. 2.
25	7545	49.58	15105	9.54	4591
25	7553	55.05	17400	20.975	6702
25	7577	58.77	19065	34.80	10142
25	7585	65.23	22388	34.80	10146
25	7681	69.93	24854	34.80	10146
29.85	8808	75.35	28090	34.80	10147
29.97	8804	80.10	31211	34.80	10147
29.97	8825	85.48	35173	34.90	10153
		90.00	38441	34.90	10164
		94.95	42353	34.90	10164
		100.51	47483	34.90	10168
Series No. 2.	Soda glass bomb.			34.90	10176
0°	3249			34.90	10178
0	3253	Series No. 2.	Steel bomb No. 1.	44.81	13337
0	3256	29.75	8728	44.813	13382
0	3261	29.75	8754	54.88	17324
0	3272	29.75	8755	54.883	17351
29.85	8763	29.75	8742	64.88	22095
29.85	8782	29.75	8720	75.065	27880
		29.75	8752	75.197	27980
		29.75	8752	85.21	34762
		39.82	10102	85.365	34933
		49.86	11652	95.46	42887
		34.77	15236	95.651	43113
		44.82	13380	100.306	47253
		54.857	17336	104.970	51739
		59.91	19593	105.07	51743
		64.92	22103	109.87	56718
		70.10	24925	115.009	62416
		75.05	27888	115.01	62328
		80.14	31155	62332
		85.26	34825	62343
		90.46	38809	119.917	68173
		95.60	43035	125.00	74686
		100.84	47602	125.00	74733

stirring of the liquid under measurements and in addition the apparatus was so arranged that the vapor phase could be pumped away from time to time. It was found to be a difficult matter to secure equilibrium at the lower temperatures and this difficulty was accentuated owing to the fact that the bath surrounding the liquid ammonia could not be maintained as

constant as desirable. A direct determination of the boiling point was therefore undertaken employing varied conditions of boiling for the purpose

TABLE V.¹—EXPERIMENTAL DATA REDUCED TO ROUND TEMPERATURES.

-33°.		0°.		20°.		25°.		30°.		35°.			
778.2	760.8	Mean	3255	6477.7	7545	8847.0	10206.6						
779.7	762.1	Calc.	3251	6477.1	7553	8811.8	10169.0						
786.9	758.2			6475.0	7577	8832.8	10166.7						
777.3	757.7			6492.0	7585	8802.0	10182.1						
772.9	754.7			————	7581	8821.0	10205.2						
773.2	781.5		Mean	6480.4	7602	8787.5	10204.2						
771.8	777.4		Calc.	6486.8	————	8787.5	10200.2						
773.6	779.7				Mean	7574	8773.2	10204.2					
754.4	770.5				Calc.	7584.9	8806.8	10205.2					
753.1	779.6					————	————	10207.1					
752.9	778.2					Mean	8808	10193.1					
747.6	782.6					Calc.	8819	10205.1					
751.9	781.2							10197.1					
764.2	778.5							10193.1					
Mean 769.3								Mean 10196.0					
Calc. 768.4								Calc. 10199.5					
40°.		45°.		50°.		55°.		60°.		65°.			
11739		13417		15271		17378		19645		22268			
11716		13445		15291		17399		19635		22145			
11710		13405		15293		17403		————		22158			
————		13449		————		————		Mean 19641		22177			
Mean 11722.0		————		Mean 15292.0		Mean 17393.0		Calc. 19682		————			
Calc. 11735.0		Mean 13429.0		Calc. 15324.0		Calc. 17380.8				Mean 22187			
		Calc. 13448.0								Calc. 22167			
70°.		75°.		80°.		85°.		90°.		95°.			
24894		27872		31143		34821		38441		42396			
24868		27857		31060		34634		38444		42522			
————		27840		————		34608		————		42492			
Mean 24881		27857		Mean 31102		34665		Mean 38443		42557			
Calc. 24912		————		Calc. 31119		————		Calc. 38426		————			
		Mean 27857				Mean 34640				Mean 42524			
		Calc. 27854				Calc. 34593				Calc. 42600			
100°.		105°.		110°.		115°.		120°.		125°.		132.9°.	
47013		51674		56858		62321		68274		74708		Calc. 85352	
46827		51769		Calc. 56839		62406		Calc. 68223		Calc. 74489			
46971		————		————		————		————		————			
————		Mean 51769		Mean 62364		————		————		————			
Mean 46934		Calc. 51698		Calc. 62323		————		————		————			
Calc. 46954													

¹ The mean value, 3255 mm., for the vapor pressure of ammonia at 0° depends on the measurements made in the soda glass series 2. The series 1 measurements are neglected because it occurred to the writers to tap the bomb during measurements after the measurements had been completed. Those data marked x in the table have not been included in the mean because they seemed to be effected with a huge error. It is likely that an error was made in reading the resistance thermometer bridge resistance.

of comparison with the manometric measurement. The apparatus was constructed with reference to a particular Beckmann thermometer which could be surrounded with beads as well as a polished platinum radiation screen, while at the bottom of the boiling vessel a small coil of wire was arranged to supply heat electrically to the liquid ammonia. The Beckmann thermometer was compared with a platinum resistance thermometer in a separate Dewar tube of sufficient size to accommodate the two instruments, at approximately the same temperature as that during the boiling-point measurement. Table VI gives the data taken and a supercooling of

TABLE VI.

Direct Determination of Boiling Point. Barometer Corrected 760.5.

Reading of current flowing through pt. spiral	Beckmann thermometer.	Temperature corresponding to 760.5 mm.
No current.....	1.37	—33.13
1 amp.....	1.33	...
	1.32	—33.18
	1.34 after 10 min.	—33.16
1.3 amp.....	1.30	...
	1.30 after 3 min.	...
	1.30 after 2 min.	—33.20
2 amp.....	1.26	—33.24
	1.26 after 2 min.	...
	1.25 after 3 min.	—33.25
4 amp. platinum wire at red heat....	0.80	—33.70
	0.90	—33.60
Addition of platinum sponge:		
No current.....	1.37	—33.13
1 amp.....	1.32	—33.18
	1.324	—33.18
	1.31	—33.19

Calibration of Beckmann with Plat. Res. Ther.

Reading Beckmann.	Temperature pt. res. therm.
1.360	—33.143
1.360	—33.141

the liquid appears to take place as more vigorous boiling is induced by means of the electrically heated wire. When particles of platinum sponge were introduced evidently no material change in the boiling temperature was produced. It is clear that the boiling point with the platinum wire at a red heat would probably dissociate the vapor to some extent, in contact, to nitrogen and hydrogen in which event the lowering of the boiling point would be accounted for. With no current passing through the wire on the other hand ebullition did not occur, while one to two amperes caused a gentle to vigorous ebullition. It seems reasonable to assume that —33.2 is very close to the normal boiling point or corrected to 760 mm. of mercury —33.21. The mean of the manometric measurements leads to —33.25, while the smoothed vapor-pressure curve, giving weight to all the higher

pressure measurements, gives the temperature —33.22 as the normal boiling point. To compare with this value are measurements due to Brill¹ —33.1, Gibbs² —33.46, Perman³ and Davies —33.5. The datum of Gibbs was taken with a pentane thermometer—an instrument not as easy to control as the thermocouple used by Brill. It should be pointed out, however, that Brill's results may be in error due to employing Dalton's law for computing the partial pressure of the ammonia vapor in the air drawn over the liquid ammonia. As has been stated above there is not sufficient data available concerning pressure-volume properties of mixtures of air and ammonia to evaluate the error likely to be introduced by this assumption. At the lower temperatures the error introduced by the assumption of Dalton's law undoubtedly becomes small.

The method used to obtain an equation connecting the pressure and temperature has been described elsewhere.⁴ The method has been applied in principle by H. Happel⁵ and also Lionel Marks⁶ and depends on finding an accurate empirical expression for a in van der Waals' formula $\log p_c/p = a(T_c/T - 1)$ where p_c and T_c are the critical pressure and the critical temperature. The values of a show a minimum when a graph is constructed with $(T_c - T)$ as abscissas. The a values were assumed capable of accurate representation by means of the series formula

$$a = a_0 + a_1 (T_c - T) + a_2 (T_c - T)^2 + \dots + a_n (T_c - T)^n.$$

a_0 is nearly 3 and may be determined in any case by an extrapolation through $(T_c - T)$ or zero of a special graph wherein the vapor pressures near the critical point are treated. The a_0 for ammonia came out 3.02 and to avoid the minimum of the direct graph a new function, Z , was defined.

$$Z = a - a_0/T_c - T = a_1 + \dots + a_n(T_c - T)^{n-1}$$

The equation of Z can be easily determined and proved to be a quadratic function. The vapor-pressure formula of van der Waals written in terms of the Z function and the critical temperature becomes

$$\log p = -[Z(T_c - T)^2 + \omega]/T + m,$$

where ω is $a_0 T_c$ and m is $(\log p_c + a_0)$. This form of the vapor-pressure equation is most convenient for calculating pressures since the $Z(T_c - T)^2$ expression may be computed with sufficient accuracy by means of a slide rule. If desired the critical temperature may be absorbed in the constants of the equation.

¹ *Ann. Phys.*, [4] 21, 170 (1906).

² THIS JOURNAL, 27, 851 (1905).

³ *Proc. Roy. Soc. London, A* 78, 28 (1906).

⁴ "Thermodynamic Properties of Ammonia," Keyes and Brownlee, Wiley & Sons, 1916.

⁵ *Ann. Phys.*, [4] 13, 340 (1904).

⁶ *J. Am. Soc. Mech. Eng.*, 33, 563 (1911).

$$\log p = -b/T + c + dT + eT^2 + \dots$$

The latter equation¹ is more suitable for differentiation for the purpose of computing dp/dT for use in the Clapeyron formula.

The measurements appearing in Table V have been used to prepare the graph, Fig. 6, where Z 's are plotted as ordinates and $(T_c - T)$ as abscissas. A few of Brill's law temperature measurements have been incorporated in the graph and also the boiling point calculated from the vapor-pressure equation given by Holst.² The data of Regnault, Brill

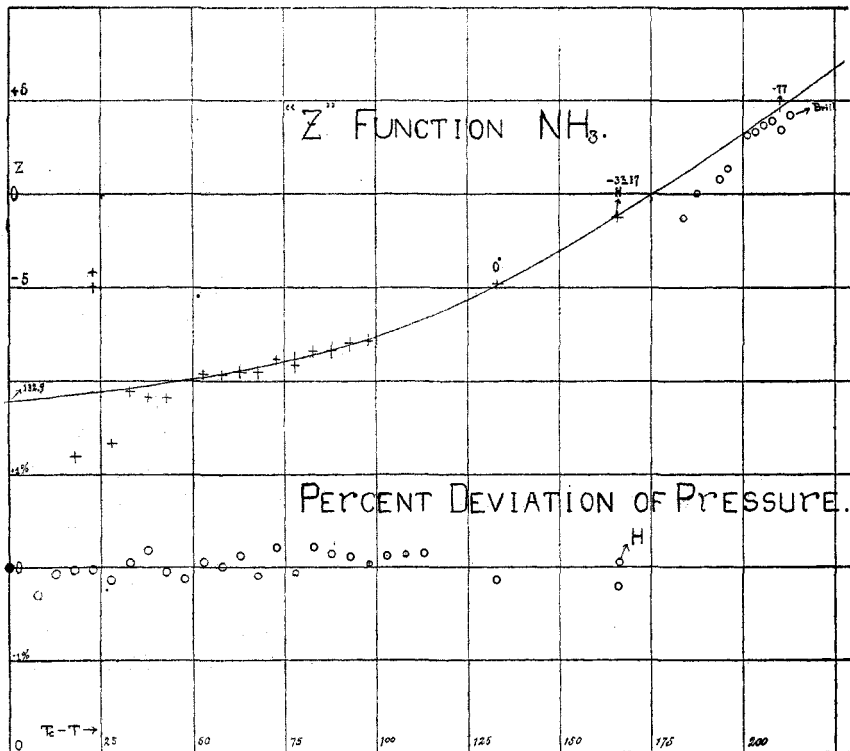

Fig. 6.

and Davies together with a few new measurements due to Holst himself were used by Holst for his formulation. The temperature at which the pressure is one atmosphere is -33.17° according to the vapor-pressure formula given by Holst.² The most probable value accordingly for this temperature would appear to be about -33.2 . It is perceived that the line passing through the higher pressure Z values cannot be made to pass through Brill's values if -33.2 is the correct temperature for the boiling

¹ The ice point on the absolute temperature scale has been taken as 273.1° .

² "Les propriétés chimiques de l'ammoniaque et du chlore de méthyl," Leiden (1914).

point. Holst has already pointed out the inconsistency of the Brill measurements as compared with the observations of Davies.

In order not to confuse the plot made from the measurements recorded in the present paper a Z plot, Fig. 7, prepared several years ago is given, showing the relation of each observer's data to the present work. This

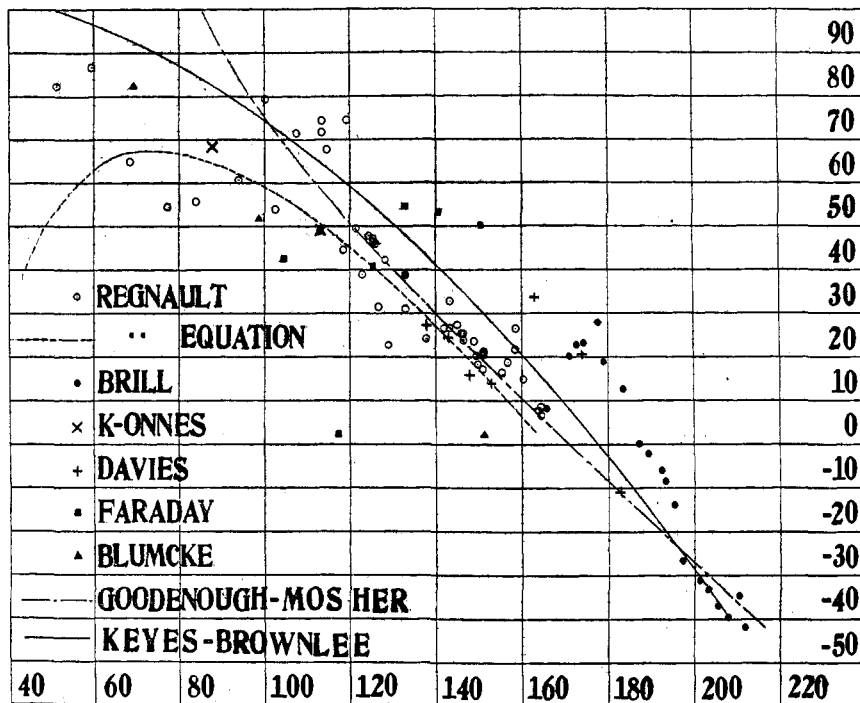

Fig. 7.

plot has drawn in it the line representing the Z equation of Fig. 6 but with different units. Since the plot is useful only as it discloses graphically differences in trend in the work of the various observers the matter of the units is immaterial. The Z equation corresponding to Fig. 6 is:

$$Z = 10^{-4} [-11.901 + 1.0018 \cdot 10^{-2}(T_c - T) + 3.2715 \cdot 10^{-4}(T_c - T)^2]$$

The vapor-pressure equations are:

$$\log_{10} p = 7.91121 - 1209.88 + Z(T_c - T)^2/T;$$

$$\log_{10} p = -1969.65/T + 16.19785 - 0.0423858 T + 5.4131 \cdot 10^{-5} T^2 - 3.2715 \cdot 10^{-8} T^3.$$

The pressure units in these equations are millimeters of mercury under normal conditions while the critical temperature and pressure are taken as 132.9° and 85355 mm. or 112.3 atm.

Recently Goodenough and Mosher¹ have made a careful examination of

¹ Univ. of Ill. Expt. Station, *Bull.* 66.

the available thermodynamic data relating to ammonia. The vapor-pressure-temperature relation was worked out with the aid of the Ramsay and Young formulas $R = R' + k(T - T')$, in which R and R' denote the ratio of the temperatures of two different substances at two different vapor pressures, and T , T' the absolute temperatures of one of the substances corresponding, respectively, to the pressures. Water was taken as the reference substance and all available ammonia vapor-pressure data used to obtain the constants needed for the Ramsay and Young formula. Fig. 7 shows that the Goodenough and Mosher equation gives values intermediate between those vapor pressures resulting from Regnault's smoothing of his own results and the values based on the present experimental work. Table VII gives the smoothed pressures resulting from the values of Table V together with the vapor pressures resulting from Regnault's smoothing of his own data.

TABLE VII.—FINAL COMPARISON OF PRESSURES.

Manometer.	t .	p . Calculated.	p . Observed.	p . Regnault.	% Deviation.
Manometer.....	-33.22	760	760.8
Boiling point.....	759.6
Absolute gage.....	0°	3251.0	3255.5	3183.3	-1.0
	10	4656.7	4574.0	-1.78
	20	6486.8	6480	6387.8	-1.68
	25	7584.9	7574
	30	8819.0	8808	8701.0	-1.34
	35	10199.5	10196
	40	11735.0	11722	11595	-1.20
	45	13448.0	13429
	50	15324.0	15292	15158	-0.92
	55	17380.8	17393
	60	19682.0	19641	19482	-1.01
	65	22166.7	22187
	70	24912.0	24881	24675	-0.95
	75	27853.5	27857
	80	31119.0	31102	30843	-0.89
	85	34593.0	34640
	90	38426.0	38443	38109	-0.83
	95	42600.0	42524
	100	46954.0	46934	46608	-0.74
	105	51698.2	51769
	110	56839.0	56858
	115	62323.2	62364
	120	68223.0	68274
	125	74488.6	74708
	132.9	85351.8

4. Summary.

The vapor pressures of ammonia have been measured from 0° to the critical temperature by means of the absolute piston gage. The normal boiling point has also been measured using both the manometric and dynamic

methods. The latter method is believed to give the most accurate value for the normal boiling temperature ($-33.20 \pm 0.05^\circ$).

A method for examining the consistency of vapor-pressure data is used whereby it is possible to obtain easily an accurate formula connecting pressure and temperature over any desired temperature range. The equation for the vapor pressure of ammonia from the freezing point (-77) to the critical temperature (132.9) is,

$$\log_{10} p = -1969.65/T + 16.19785 - 0.0423858 T + 5.4131 \cdot 10^{-5} T^2 - 3.2715 \cdot 10^{-8} T^3,$$

where the pressure units are mm. of mercury under normal conditions. The pressures given by this equation represent the experimental data within the limits of experimental error but they are the order of one per cent. higher than the values decided upon by Regnault.

An improved method of electrically determining the weight necessary to equilibrate the force due to the mercury column used in the absolute piston gage calibration is described. The electrical contact method decreases the time needed to make observations with the piston gage as well as enormously increasing the sensitiveness.

CAMBRIDGE, MASS.

[CONTRIBUTION FROM THE CHEMICAL LABORATORY OF THE UNIVERSITY OF CALIFORNIA.]

THE VAPOR PRESSURES OF LIQUID METALS.

By JOEL H. HILDEBRAND.

Received November 14, 1917.

A valuable paper on the vapor pressures of metals was recently published by Johnston.¹ In addition to summarizing the existing data he has calculated for each metal the constants of the vapor-pressure equation, $\log p = -A/T + B$, and the heat of vaporization, which is 4.58A. In view of the inaccuracy of much of the data involved it has seemed to the writer that it would be useful to attempt to correct these calculations by applying the rule discovered by him² that the entropy of vaporization (*i. e.*, the heat of vaporization divided by the temperature of vaporization on the absolute scale) is the same for all normal liquids, provided that the comparison is made at temperatures where the saturated vapors have the same concentration. It is to be noted that this differs from the familiar Trouton's Rule in that the comparison is made at temperatures of equal concentration of saturated vapor instead of at temperatures of equal vapor pressure, such as the boiling points. It has been shown that this generalization makes it possible to superimpose the vapor-pressure curve for one substance upon that for another by the aid of a

¹ Johnston, *J. Ind. Eng. Chem.*, 9, 874 (1917).

² THIS JOURNAL, 37, 970 (1915).